

An Investigation of Traditional Turkish Wooden Houses

Nimet Öztank

Assistant Professor, Torbalı Vocational School of Higher Education, Dokuz Eylül University, Turkey

Abstract

Wood is one of the oldest materials used for building different types of structures in many parts of the World. Turkey is a country with a wide range of building traditions and traditional houses are the most important evidence of the past life style. Traditional houses in Turkey were built mostly of wood, and timber-framed building systems have frequently been used and were common there until the 20th century. While new buildings in rural areas used traditional techniques until the middle of the last century, thanks to the development of transportation and availability of modern materials such as cement and industrial bricks across the country, the construction of traditional timber-framed houses has declined considerably. This change in modern methods of building has resulted in a loss of knowledge concerning the tradition of wooden buildings. In this study, the general structural and architectural features of traditional Turkish timber-framed houses are introduced and their layouts, plan types and frame details are presented in terms of the use of wood in construction. This study is based on observations, literature and on-site investigation.

Keywords: traditional house; wooden houses; wood frame; architectural and structural features

1. Introduction

In Turkey, most housing built prior to the 20th century used wood as the major structural material. There are several studies that deal with the architectural characteristics of traditional dwellings in Turkey, but those which deal with the structural characteristics of traditional wooden dwellings are inadequate. Wood construction systems have been used in traditional Turkish architecture, and according to Ahunbay's, research on Turkish houses, timber frame construction was developed in the seventeenth century, and used continuously thereafter (Ahunbay, 2000). There are houses of one or more stories in the cities and towns. From the middle of the 20th century, modern technology took the upper hand in the construction industry in Turkey and thanks to the development of transportation facilities and the availability of modern materials such as cement and industrial bricks across the country, the construction of timber-framed buildings has declined considerably. These changes towards modern techniques of building have resulted in the loss of knowledge concerning the traditional method of wood-based building activities.

Variations on the traditional wooden house in Turkey include village houses, urban houses and other types

of houses. The other types of houses are different from the common types and are usually carefully constructed on an imposing scale and display extremes both in their environmental elements and their interior arrangements. They may be listed as follows: large multi-purpose imposing mansions, summer residence villas set in open country and gardens and with picturesque views, waterfront houses; "yalı", well-protected large mansions; "kasır" and palaces; "saray", serving as residences for senior officials built on a larger scale and with great elaboration (Küçükerman, 1985). Traditional wooden houses differ according to mass, plan, façade element and ornamentation. However, they share similarities in terms of construction technique. In this study, the general structural and architectural features of the traditional timber-framed houses are introduced and their layouts, plan types and frame details presented in terms of the use of wood in construction. To achieve this study, some researches based on observations, literature and on-sight investigation were carried out. The traditional houses in Turkey, which constitute the subject of this study, were mostly constructed after the seventeenth century.

2. Structural Features

Traditional timber-framed houses consisted of a masonry basement and upper floors with frame and roofs made of wood. The basement walls served not only as a foundation for the houses, but also as barriers to the moisture exuding from the ground. The thickness of the walls varied between 80cm and 150cm. As

*Contact Author: Nimet Öztank, Torbalı Vocational School of Higher Education, Dokuz Eylül University
Atatürk Sanayi Sitesi 35860 Torbalı/Izmir, Turkey
Tel: +90-232-853-1828 Fax: +90-232-853-1606
Email: nimet.oztank@deu.edu.tr

(Received October 8, 2009 ; accepted March 3, 2010)

mentioned above, these walls were built up to the ground-floor level and most were load-bearing. The surfaces of the walls on the ground floors were usually retained without plaster, while the stones used to build them were either obtained from nearby quarries or collected from streambeds.

The basement and ground floors were constructed of masonry, whereas the upper floors employed the timber-framed system. The filling of this frame consisted of daub, rubble stone and unfired or fired bricks. The construction of the upper floors consisted of a wood frame, which was provided by studs placed 30–90cm apart and framed by 15x15cm posts. These posts were supported by diagonal and horizontal braces.

An important element of the timber-framed construction system is the diagonal and X braces (Fig.1.). In general, these elements are included in the system with 30° and 40° inclinations to support the posts on the corners of the building. They are placed in such a manner that their upper end and joints are a little higher than the centre of the corner post. They contact the stud near the window and then reach the base. The timber-framed members and braces are bound to the system with nails. Although there are notches on the bottom ridge plates for connection with braces, in general, we can say that no tenon technique or other similar joining detail is used in the system.

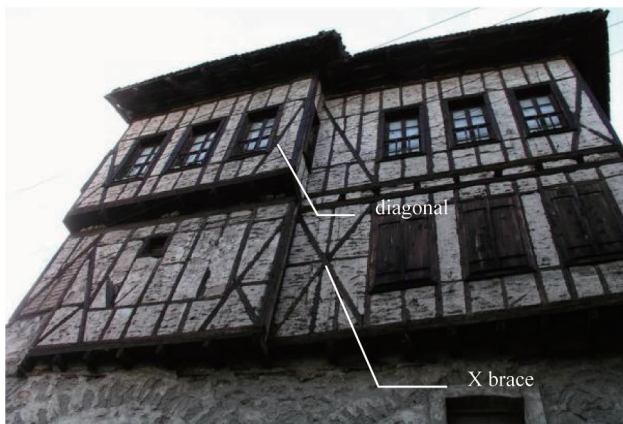

Fig.1. Diagonal and X Braces were Used to Stabilize the Panels¹

Historically, two general types of timber-frame have been used;

- I) Timber frame
 - a- Hımiş construction - Hybrid construction
 - b- Dizeme construction
 - c- Bağdadi construction - Lath technique
- II) Combined construction

2.1 Timber Frame

The timber-framed building technique is executed by filling or covering the gaps between the wooden frame and the posts, in addition to those between the beams of the wooden frame.

A-Hımiş Construction–Hybrid Construction: The main construction system of traditional timber-

framed buildings in Anotolia is the hybrid construction technique, namely *Hımiş* in Turkish (Güçhan, 2007). Hımiş construction is simply described as a wood frame with masonry infill, such as bricks, adobe or stones. This type of construction is a variation on a shared construction tradition that has existed through history in many parts of the world, from ancient Rome almost to the present. In Britain, where it became one of the identity markers of the Elizabethan Age, it was referred to as "half-timbered." (Doğangün, 2006). The house constructed with the "Hımiş" technique consists of three parts as follows (Fig.2.):

- 1- Masonry basement and ground floor
- 2- Timber-framed section (floor/floors)
- 3- Timber roof

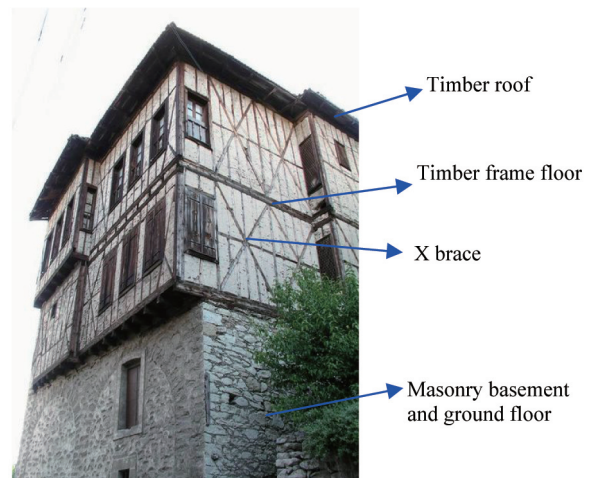

Fig.2. Traditional "Hımiş" House in Safranbolu, Turkey¹

The basement and ground floor composed of massif were made either entirely of stone or stone and adobe, based on the local availability. The external wall of the basement floor, which was constructed on a stone base, was strengthened against horizontal loads by connecting with the wooden lintel that was placed at regular intervals. The internal and external surfaces of the ground floor walls were enclosed by sole plates, and then it continued with timber frame for the upper part of the structure. Beams and joists were placed on the sole plate.

B- Dizeme construction: The construction is called "Dizeme" if wood is used as filling material in the hımiş construction system. In some buildings, wood was used as infill material instead of masonry, particularly in some regions that abound in wood. Short rough wood elements, called dizeme which were lightly nailed studs or horizontal framing elements, were used as infill in this type of construction (Fig.3.). The purpose of wood infill was to avoid the common early shear failure and severing of the frame that occurred with masonry infill (Doğangün, 2006).

C-Bağdadi construction-Lath technique: In addition to the use of stone, mud brick, brick or wood as infill material, another widely used technique is the

"Bağdadi"-lath-technique. The bağdadi approach is a construction type where the voids between the framing wood members are filled with lighter materials or with trunk shells transformed into a filling material by the addition of sand and lime mortar. The interior surfaces of walls were covered by lath and plasterwork or wood, whereas the outer surfaces were plastered, non-plastered or wooden-plastered (Fig.4.).

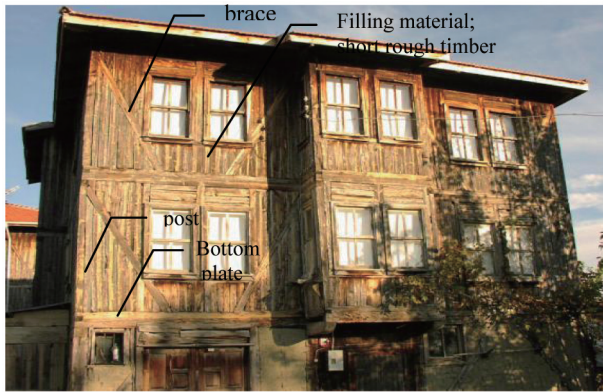

Fig.3. The Traditional Timber-framed House with Wood Infill: "Dizeme Construction"¹⁾

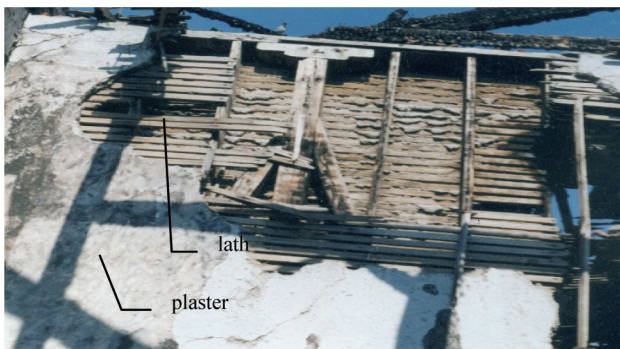

Fig.4. The "Bağdadi"-type Construction (Photo by the Author)

Wall materials, such as stone, brick and mud brick, usually cause damage to the buildings during earthquakes, as they add extra load to the structure or, in some cases, because they have weak binding mortars. However, in the bağdadi technique, the wood laths increase the resistance of the building against lateral forces (Güçhan, 2007).

2.2 Combined Construction

This construction is a composite application of both the timber frame and masonry wall techniques. The role of the wood frame is to support the stone wall, to tie the first-level-story timber frame onto the lower story and to serve as support to the first-level-story overhang. The houses constructed by this technique have one or two stories. All external walls of the basement floor and first floor are constructed using the combined construction technique (Oztank, 2008). This technique consists of an interior timber-framed system that is joined to the outer masonry wall of the structure which was made of rubble stone and brick (Fig.5.). The thickness of the exterior wall is around 50–65cm.



Fig.5. General View of Combined Construction, A: Kılıcı Mescid, B: Murat Residence, Izmir/Turkey (Photo by the Author)

A timber frame, constituting the exterior wall, consists of square-section posts placed every 150cm and rectangular section X braces placed between them.

The masonry wall serves as a filling for the spaces in the wood frame. The walls are plastered with lime mortar.

All interior walls are constructed using wooden frame and the interior-wall thickness is approximately 17cm. The frame of the interior wall consists of square-section posts, and rectangular section studs placed every 30–40cm and roughcast is applied on all interior walls. Timber frames are filled with bricks and stone and then plastered or both sides of the construction are coated with lath strips and plastered instead of being filled.

2.3 Structural Details of Traditional Timber-framed Houses

Post: The frame posts were placed on sole plates with spaces of 1.5 to 4 meters between them. To create windows, bay studs were located between posts when the windows were too close to the corner or to each other. Top rails were very common on posts. Posts and corner posts were joined with braces from both sides. The post and beams usually had square sections, whereas studs, joists, braces and other frame elements usually had rectangular sections. Especially in the rural areas, trees were used without any processing; the only process used was bark removal. These round cross-sectional elements were used for the frames and roofs.

Beam: Floor beams are spaced at 40-60cm intervals, parallel to the short side of the room. Generally, beams with 20x25cm or 25x25cm sections are placed within the system facing the same direction. The

spatial dimensions are usually determined according to the size of available materials, whereas in some larger spaces such as the hall long wood beams with a relatively larger cross-section are used. Intervals between beams, which can be observed from the façade of the buildings, are filled with stone pieces if they are not covered with frame boards.

On the ground floor, the ceiling is left bare, and the beams and joists are clearly obvious (Fig.6.a). The beams and joists are covered on the top by 20-40cm wide and 3cm thick wood boarding (Fig.6.b). In some houses, the ceilings are covered by 25 or 30cm wide wood, the joists of which are covered by profiled laths (Fig.6.c). The first floor is generally made up of beams, and joists are scattered among them. The outer surfaces of the joists were covered with wood board. Boarding with wood planks for room floors is the common building technique of timber-framed houses. In this type of boarding technique, all the planks are nailed side by side, while usually, the ceiling planks are fixed on to the beams diagonally or horizontally for decorative purposes. The total flooring height is about 30cm, and the story height is 350-450cm. The lathing of the ceilings is mixed with lime plaster (Fig.6.d).

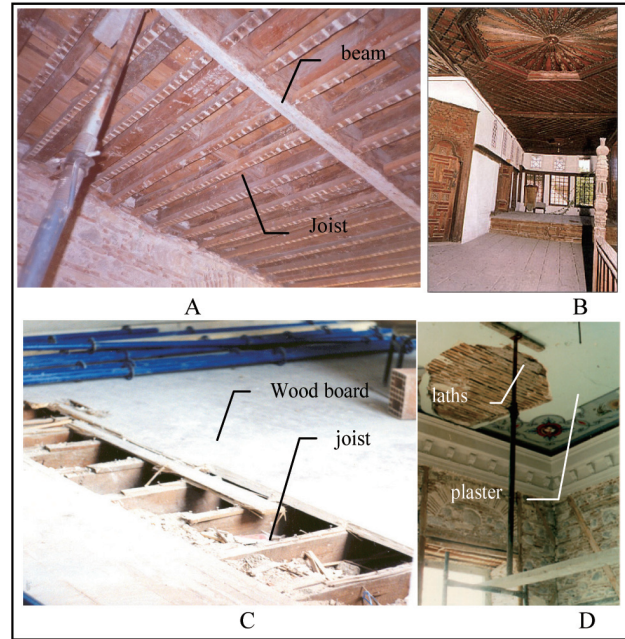

Fig.6. a) Detail of the Ground Floor Ceiling. b) Detail of the Ceiling; Covered with Wood c) Detail of the First and other Floors. d) Ceiling; the Lathing is Mixed with Lime Plaster (Photo by the Author)

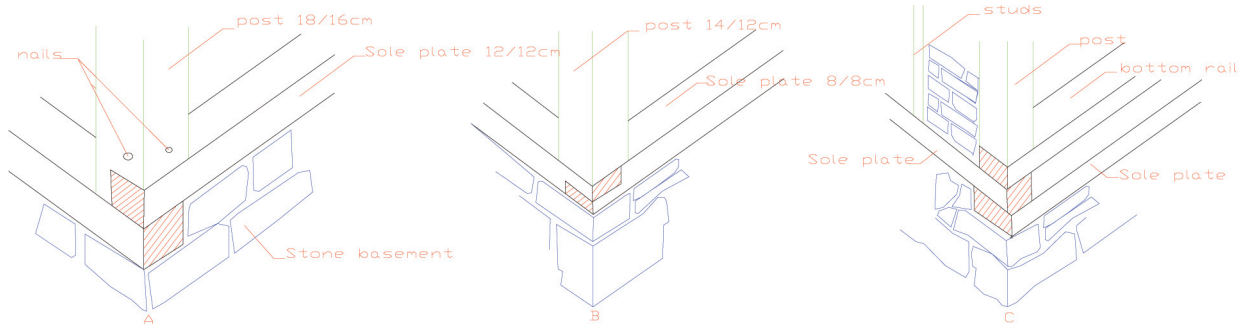

Fig.7. Details of Sole Plate on Base A and C: Lap Joint; B: Half-lap Joint (Aksoy and Ahunbay, 2005)

Plate and rail: A timber frame was always placed on the base using a sole plate (Fig.7.). On the first floor, and second floor (if it existed), the building's head binders were, single binder or single binder on one side with a double binder on each side (Fig.8. a-b) or double binder on the other side (Fig.8.c), such as the lower head binder.

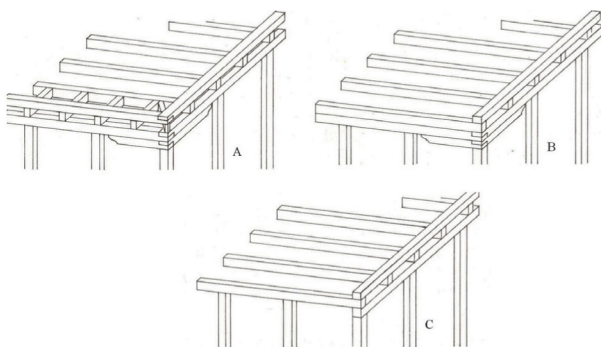

Fig.8. Detail of Joists and Head Binder at the Corners (Günay, 1998)

If the building had projections on the upper floor, different types of construction techniques were used; for example the floor joists were extended. Generally, cantilevered projections were used and built in such a manner that the load-bearing girders belonging to the upper floors were cantilevered 60–100cm. from the building's façades at the end point of the cantilevered projections. A bottom rail was placed on the ends of the extended floor joists and then the posts were placed on this bottom rail (Fig.9.a). Occasionally, cantilevers were supported with an angle brace aligning the post and studs (Fig.9.b). In some examples, the girder elements were supported with a second beam. The woods used for creating the frame were always one-piece samples. Only the sole plate was subjoined. When making an addition to the sole plate, a scarf joint was used, as shown in Fig.10.a. Especially for the single—sole plate constructions that were built by the overlapping technique, groove assembling was used as an addition to nails while assembling the post and studs to the sole plate, as shown in Fig.10.b. In Fig.10.



Fig.9. Details of Projections (Photo by the Author)

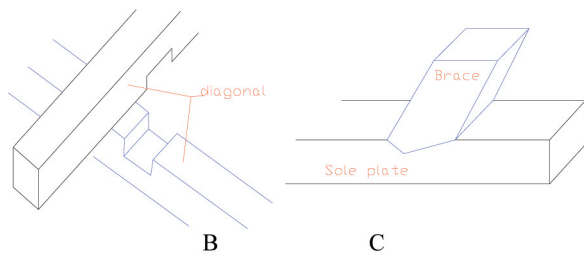

Fig.10. A: The Sole Plate Jointing-scarf (splayed) Joint, Afyon
 B: Sole Plate and Brace-notch Joint C: X-brace Spider-joint

c, X braces are shown connected to each other through the double side notching spider-joint method.

In traditional structures, the bonding of braces to the bottom plate and angle brace of the cantilever or oriel to beams were forged as tonguing or tongued-and-grooved joints. Tongued and grooved joints were used to connect angle braces to the floor. Sometimes the frame elements were joined together by nails (Fig.11. a). In addition to joining by nails, various other joining techniques were also used for bonding the joists to each other, the corner posts to the bottom rail, top rail to the posts and studs, the roof elements to each other and angle brace to the beams. As shown in Fig.11. b, nail and joint techniques were used together for connection of the headings, which were placed on the post.

Roof elements: The timber frame was completed with the roof truss that was placed on the top rail of the wall frame. Generally, the beams of the roof structures end at the outer edges of the surface walls.

The timber-framed roof structure was set on the main roof girders, which were placed along the axis of the ridge purlin above the ceiling beams. The posts and studs were placed along the full length of the ridge purlin and tied to it.

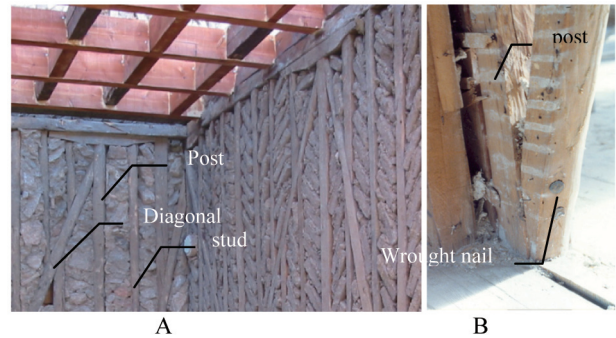

Fig.11. A: Post and Top-rail Joint, Afyon/Turkey.
 B: Post-and-brace Joint Accomplished with Wrought Nail (Photo by the Author)

The ridge purlin was tied to the corners of the structure with the angle rafters determining the slope of the roof, and the opening between the ridge and the rafters was horizontally divided into equal intervals by the purlins. According to the roof construction, ridge beams may be found in horizontal or slope arrangements. Roof posts have no collars or struts, and usually, rafters rest on the ridge beams and purlins. Roof boards of 2.5 to 3cm thickness were placed on the rafters, and the over- and under-type tiles were laid on the roof board. In the construction of the roof, nails were used at the joints.

3. Architectural Features

The timber-framed houses were generally built for extended families and were usually side-by-side, back-to-back or adjacent to each other (Fig.12.). Some are detached houses like a villa, mansion and residence. The majority of traditional houses were been built on plots that are bordered by streets developed in conformity with the natural characteristics of the landform. The timber-framed houses changed according to the size of the plot of land and constituted a different plan type. They generally consist of a ground floor, first floor and other floors, attic room and roof.



Fig.12. Traditional Row Houses, Afyonkarahisar/Turkey

The houses have traditional architectural characteristics in their façades and architectural elements, and have a large bay window and overhang that has windows on each side, on the floors and are situated directly on streets or in gardens. Due to the

topographic conditions the houses with gardens had entrances directly from the streets or the gardens and usually had courtyards. Most of the household's production activities and many of the daily functions such as eating, cooking, and gathering with neighbours, take place in this area. The doors, staircases, fountain, pool and well are the main architectural elements of the courtyard. Access to the ground floor and first floor is through stairs from the courtyard (Fig.13.). Like a courtyard, the "Taşlık" is a circulation space at ground floor level in some of the traditional houses. It is a semi-closed space that connects street to courtyard and gives access to service spaces and to the upper floor as a part of the house.

Except for the single-story housing units, the ground



Fig.13. The Yard, Service Place and Stairs of a House in Muğla

floor comprises spaces, such as courtyard, a stone-paved open hall (Taşlık), the service place (kitchen, warehouse), restroom and the stairs that lead to the upper floors. There is a differentiation between the ground floor and the upper floors in traditional houses; the upper floors are allocated for living areas formed by rooms oriented around or towards the sides of a hall, and the upper floors are much more detailed than the ground floors. The second floor usually has the same plan and plan elements as the first floor. The living rooms and summer rooms are on the first floor, while all floors have both rooms and semi-closed spaces. The rooms have simple cupboards, fireplaces, shelves (Fig.14.a) and niches (Fig.14.b).

3.1 Plan

The ground floors have special plan arrangements due to their functions, which are different from the upper floors. The ground floors are also altered. Therefore, to determine the plan type, the upper-floor arrangements are considered. The traditional timber-framed house has three fundamental spatial elements which form the structure. These important elements are the room, the hall "sofa" and the "eyvan" (space between the groups of rooms). The "room" is accepted as the main element, which does not show any difference in usage as it is a space with many functions for many purposes (Ozdemir, 1998).

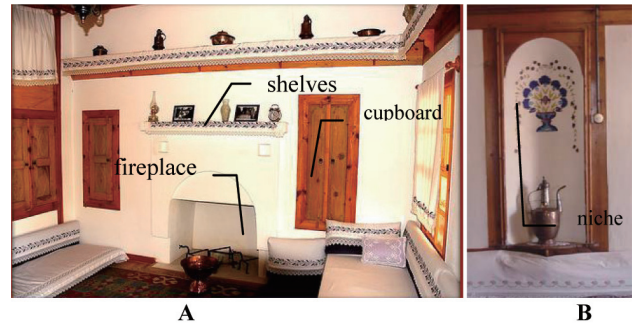

Fig.14. A: The Rooms have Simple Cupboards Fireplaces and Shelves. B: A Niche in the Wall in The Karaoğuz Pavilion, Beypazarı/Turkey (Gültekin, 2007)

The plans can be grouped according to the number of rooms, services and the shape and location of the hall. The hall simply means the common area between the rooms, which provides access between open and closed areas. Many of the daily activities occur in this space due to its semi-private character, which is a square or rectangular space. The halls are either semi-closed (Fig.15.) or closed spaces. In temperate regions, the semi-closed halls and, in other places, closed halls are noticeable.

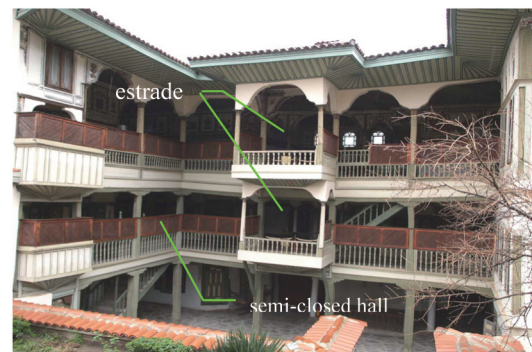

Fig.15. The Semi-closed Hall of "Çakırağa" Residence, Birgi/Turkey (Photo by the Author)

The first classification of traditional dwelling units according to their plan typology was attempted by Sedat Hakkı Eldem (1952, 1955, 1984). The hall, a semi-closed or closed space shared by the members of the family, is the basis of this typology. This classification gives four types of houses: "Without a Sofa", "With an Outer Sofa", "With an Inner Sofa" and "With a Central Sofa" (Eldem, 1984) (Fig.16.). The houses "without a Sofa" are seldom built with a wood-frame.

3.2 Roof

If we look at the types of timber-framed houses, three types of roofs can mostly be observed. The most common are pitched roof, hip roof and the gable-type roof. The roof plan is square or rectangle and covered by Turkish tiles and zinc plates, rarely by wood shingles. Generally, there is no gutter; the water runs down the roof freely. While some houses have a roof room, it has no influence on the roof type.

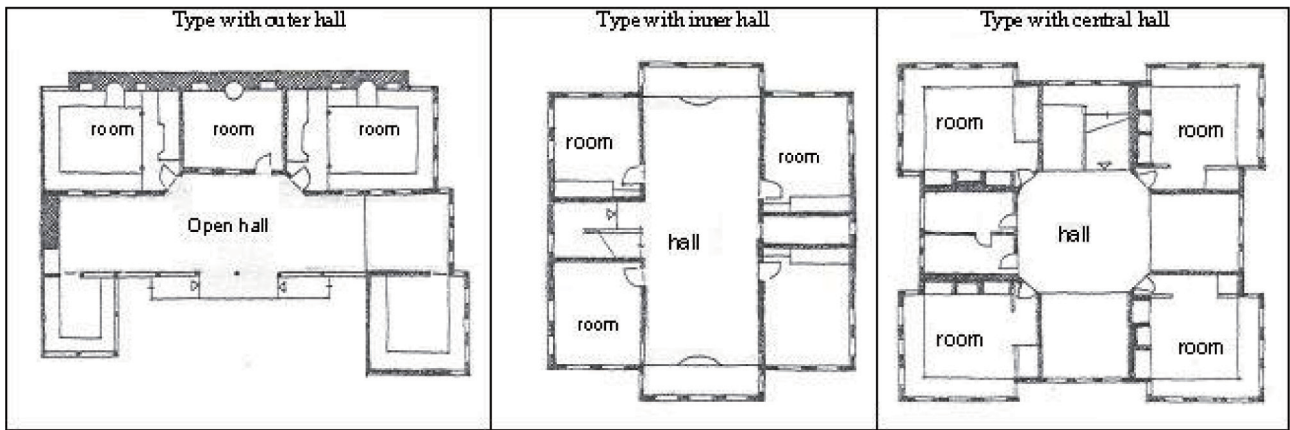

Fig.16. The Composition of Rooms on the Sides of the Hall Determines the Plan Type

The room may be located in the middle of a hipped roof, pitched roof or a gable roof and has a special influence on the façade of the building (Fig.17.).



Fig.17. Roof Room Located in the Middle of the Roof

3.3 Façade

Traditional house façades are usually symmetrical and such symmetry is evident both horizontally and vertically. The height of the houses, the number of stories, the placement of the entrance doors, windows, projections and roofs compose the expression of the façade. The two-winged entrance door, which is generally in wood and ornamented, is the main element on the ground floor. The windows are the other important elements that affect the arrangement of the façade. The downstairs windows are kept smaller than the ones in the upstairs, and also have metal and wooden bars for reasons of security. The second and other floors are generally bay-windowed. These bay windows both maintain a symmetrical structure of the houses and economize on space. While the entrance is on the right or left side of the houses if it is under the bay window, it is in the middle and opens onto the courtyard of the house without a bay window. Windows are architectural features permitting communication between private and public spaces. Related architectural features of the window are shutters and lattices, maintaining both privacy and visibility at the same time (Fig.18.).

Timber-framed houses generally have projections on the first or other floors. A semi-open projection with



Fig.18. Generally, the Shutters, Lattices, Wood Railings or Iron Grills are Façade Characteristics of Wooden Houses

a lattice-window and a projection to the street and/or courtyard are features of the façade.

Ornamented supports under the oriel and cantilevers were also common architectural elements of these houses. The projections are formed by beams, which are supported by angle braces or have no support, depending on the width of the projection. The angle brace is used to reinforce the projections (Fig.19).

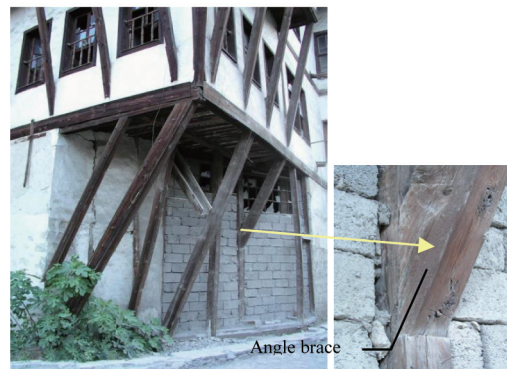

Fig.19. Examples of Timber Houses with Projection Beams¹

Due to the different projections and architectural elements, different façade arrangements are obtained;

however, in all types of façades, symmetry is observed. It is also observed that the total number of façade elements is related to the disposition and/or massing of a building. There are three different kinds of façade (Oztank, 2006).

- The roughcast form (Fig.20.a),
- The weather boarding form (Fig.20.b),
- Masonry without plastering form (Fig.20.c),

The wood weather boarding of exterior façades became widespread especially after the 19th century. In this technique, various infill materials have been used (lathing or brick) under the cladding in cases where wood lathing has been used under the weather boarding, as shown in Fig.20.b.

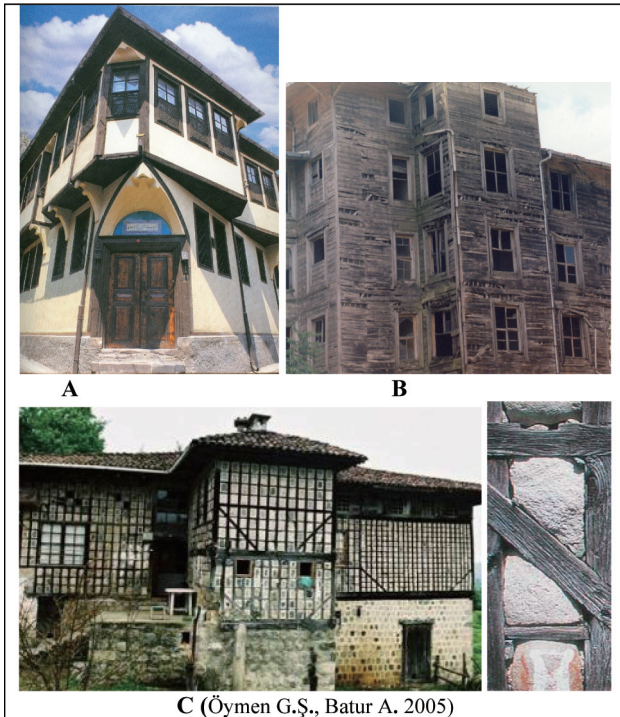

Fig.20. There are Three Different Kinds of Façade

The application of infill material is dependent on the local conditions. In most parts of Turkey, the façade frame is filled using stone and brick. In addition, eaves, pediments, profiles, below pediments, consoles and supports below projections, wood elements above and below windows and concave eaves are architectural elements of traditional houses.

4. Conclusions

This paper has aimed to introduce the structural and architectural characteristics and details of traditional Turkish timber frame houses. The types and structural properties of such houses are mainly presented under the titles of structural features, while traditional architectural features are also introduced briefly.

The benefits at the implementation phase are as follows:

- Architectural values in the traditional houses are original facade, plan types, architectural elements and settlement pattern.

- The elements affecting formation of the façade are the number of floors, horizontal and vertical bands, fullness and emptiness, symmetry, material, entrance features, window and bay window features.

- Traditional houses are made up of a masonry basement while the upper floors are constructed using wood frame and wood roof.

- In all houses, the ground floor is allocated for service spaces, whereas the upper floors are planned as living sections, formed by rooms oriented around or towards the sides of a hall.

- The wood frame of the houses consists of posts, studs, diagonal- or X braces, beams and joists.

- The filling of the frame is carried out with daub, rubble stone, wood and unfired or fired bricks.

- In traditional houses, the flooring is organised from rectangular cross-sectioned solid wood beams and joists and its upper side is covered with floor lumber.

- Usually, cantilevers using angle bracing are used in the first and other floors.

- Generally, in traditional examples, joint techniques were used for architectural elements, such as doors and windows, and nails for the timber-framed sections.

- The lath and plaster technique was used for the walls and ceilings. The lathing technique was used where the climate conditions were very mild and where large amounts of wood were available.

As a result, the expected benefit from this research is to provide data in order to carry out traditional timber frame construction. On the other hand traditional timber houses which still exist should be studied from different perspectives for evaluation and interpretation.

References

- 1) Ahunbay, Z. (2000) Timber frame building systems, Seismic behaviour of timber buildings, Timber construction in the new millennium. Workshop, co-ordinated by Ceccotti and S.Thelandersson, Venzia.
- 2) Aksoy, D., Ahunbay, Z. (2005) Geleneksel Ahşap İskeletli Türk Konutu'nun Deprem Davranışları. ITU Dergisi/A Mimarlık, Planlama, Tasarım, 4(1), pp.47-58.
- 3) Doğangün, A., Tuluk Ö.I., Livaoglu, R., Acar, R. (2006) Traditional Wooden Buildings and their damages during earthquakes in Turkey. Engineering Failure Analysis, 13, pp.981-996.
- 4) Eldem, S.H. (1955-1972) Türk Evi Plan Tipleri. İstanbul, ITU Mimarlık Fakültesi.
- 5) Eldem, S.H. (1984) Türk Evi Osmanlı Dönemi. İstanbul, TAÇ Vakfı.
- 6) Güçhan, Ş. N. (2007) Observation on earthquake resistance of traditional wood-framed houses in Turkey. Building and environment, 42(2), pp.840-851.
- 7) Gültekin N. (2007) Geleneksel Konut Dokusunda Kullanım Sürecinin Değerlendirilmesi-Beypazarı Örneği. J. Fac. Eng. Arch. Gazi Univ., 22 (8), pp.261-272.
- 8) Küçükerman, O. (1985) Turkish House. İstanbul.
- 9) Ozdemir, I.M. (1998) Space organization of Turkish house since traditional till today. IAHS Conference. Portugal, (2), pp.522-530.
- 10) Oztank, N. (2008) Traditional Wood Turkish Houses and Structural Details. 10th World Conference on Wood Engineering. Miyazaki, Japan: p.235.
- 11) Oztank N. (2006) Wood Frame Residential Constructions in Turkey and Designing Model House. 9th World Conference on Wood Engineering. Portland/Oregon, USA. p.247.
- 12) Öymen G.Ş., Batur A. (2005) Doğu Karadeniz'de Kırsal Mimari. Milli Reasürans Sanat Galerisi Yayınları, İstanbul.

Note

- 1) <http://www.ahsap.com/gallery/v/album43/sf038.jpg.htm>