



ΔΕΛΤΙΟΝ ΤΗΣ ΧΡΗΣΤΙΑΝΙΚΗΣ ΑΡΧΑΙΟΛΟΓΙΚΗΣ ΕΤΑΙΡΕΙΑΣ

The Beauty of Castles: A Tenth Century Description of a Tower at Constantinople

Henry MAGUIRE

Δελτίον ΧΑΕ 17 (1993-1994), Περίοδος Δ'. Στη μνήμη της
Ντούλας Μουρίκη (1934-1991) • Σελ. 21-24

ΑΘΗΝΑ 1994

Henry Maguire

THE BEAUTY OF CASTLES: A TENTH CENTURY DESCRIPTION
OF A TOWER AT CONSTANTINOPLE

The epigrams of John Geometres, a poet and rhetorician who was active in the second half of the tenth century, are a still insufficiently utilized source for the history of Byzantine art and architecture.

Although these poems were written in an allusive and often obscure style, they can be made to reveal both concrete information about buildings and their decoration, and also valuable insights into Byzantine reactions to works of art. In this tribute to the memory of Doula Mouriki, who was one of the twentieth-century's foremost interpreters of Byzantine monuments, I would like to discuss a tenth-century interpretation of a Byzantine structure, namely a description by John Geometres of a fortified tower. Even though the text of the poem, as it has come down to us, is incomplete, the Byzantine writer's *ekphrasis* has a special interest in that the specific building that he described still survives, and we are thus able to compare the reactions of the medieval viewer with our own.

The text, which I reproduce here from the edition by Cramer, is as follows¹:

Ἄλλοι κατοικεῖωσαν εἰς γῆν ὡς μῦες·
ὡς ἔρπετῶν χεῖριστα καὶ τῶν κνωδάλων,
τρώγλας, χαράδρας· οὐ γὰρ οἰκίας λέγω
σπήλαια καὶ σήραγγας ἢ μωξίας,
5 ἢ σαθρὰ καὶ τρέμοντα παίγνια ξύλων,
ἄθυρμα παιδῶν, ἔργα καὶ πάσης βίας,
ἄμβρων, πυρός, σεισμῶν τε βρασμῶν, πνευμάτων.
Ἡμῖν Θεὸς δέδωκε πύργον ἰσχύος,
πύργον βεβαίου, πύργον ἀρρήκτου βίου·
10 πάντων κρατοῦντα τῶν παθῶν τῶν τοῦ βίου,
καὶ βαρβάρων χειρῶν τε καὶ τεχνασμάτων·
πάντων καλῶν γέμοντα καὶ θαυμάτων·
πύργωμα κάλλους, πύργον ἀφράστου γάνους,
ἐκ γῆς, θαλάττης, ἀέρος, φωτός, πόλου·
15 κάλλους δὲ μᾶλλον κράμα τῶν ὠρῶν, ὄρον
γῆς καὶ θαλάττης δεσμός ἐστι, κἂν ὄρος
συνδεῖ κατ' αὐτὸ καὶ διεῖργει τὰς φύσεις·
ὕψος κολοσσός, καὶ τέμνων τὸν ἄερα·
βιάζεται πως καὶ πρὸς αἰθέρα φθάσαι.
20 Τὸ δ' εὖρος εὐρύς, καὶ τὸ μῆκός τι πλεόν.
Ἄμφοῖν δὲ τούτοις κάλλος, ἀλλ' ὄσον πλεόν.
Κοσμεῖ λίθους τὸ σχῆμα τετραγωνία·
ἐξαισία τις ἀρμογῆ καὶ πρὸς τρίχα
τὸ σχῆμα πύργου, σχῆμα λεπτοῦ κηρίου·

25 τὸ σχῆμα κάλλιστον ἐξαγωνία,
ἦρται πρὸς ἄστρα, καὶ τὰ κάλλη τοῦ πόλου.
Μή μοι παλαιῶν φράζε πυργοποιῶν·
ἐκεῖνος οὐπω πύργος, ἀλλ' εἶχε τέλος·
μέγιστος οὗτος καὶ πεπύργωται, μόνος
30 ἔστηκεν αὐτός, καὶ φυλάττει τὴν πόλιν.
Τέρπει δὲ μᾶλλον πᾶσαν ὄψιν καὶ πόλιν,
τῶν θαυμάτων τις χῶρος, ἀέρος μέσον
τῶν πνευμάτων τις κόλπος, οἶκος Αἰόλου·
καὶ κάλλος αὐτός, πᾶν δὲ κάλλος ὑπόθεν
35 κόσμου θεωρῶν, κόσμος ἐστὶν ὀμμάτων.
ἐκ γῆς μὲν ἄνθη, δένδρα, λειμῶνες, χλόαι,
κρήναι, δρυμῶνες, ὀργάδες καὶ λιβάδες·
ἢ δ' ἄμπελος βρίθουσα καρπῷ μυρῷ,
πολλὴ μὲν εὐθὺς ἡμερὶς μεθυτρόφος,
40 πολλὴ δὲ καὶ δενδρίτις ὠραιοτρόφος·
ἔστι δ' ὄπου καὶ μίξις ὠραιουμένη.
Ἡ δενδρὰς ἐστὶν ἄμπελος πυργουμένη·
κλάδοι κατ' αὐτὸ καὶ καλαὶ κληματίδες·
καρποὶ κατ' αὐτὸ, καὶ ῥάγες καὶ τὸ πλεόν,
45 στιβάς τε φύλλων, καὶ στοαὶ τε καὶ στέγαι.
Θέλεις τὸ πύργου πᾶν πρόσωπον μανθάνειν;
Αἶρε πρὸς ὄρθον ὄμμα, βλέπον ἐγγύθεν
τὰς ἀρετὰς γῆς· εὖγε τοῦ κεκληκότος
προφητικῶς φύσαντος οὐκ ἦσαν πάλαι...

The poem may be translated:

“Let other creatures, such as mice, live in the earth, and such as the lowest of reptiles and of beasts, in holes and ravines. I pass over dwellings such as caves, hollows in rocks, or mouse-holes, or unsound and trembling trifles constructed of (pieces of) wood, playthings of children, the victim of every form of violence, of storms, of fire, of earthquakes and tremors, and of winds. To us God gave a tower of strength, a tower of firmness, a tower of life not to be broken, overcoming all the sufferings of life and the assaults and machines of the barbarians, full of all beauties and wonders. A towered fortification of beauty, a tower of ineffable joy, from land, from sea,

1. J. A. Cramer, *Anecdota graeca a codd. manuscriptis bibliothecae regiae parisiensis*, Oxford 1841 (repr. Hildesheim, 1967), p. 278-280. The text is also contained in PG, CVI, cols. 915-916. For advice on the following translation I am indebted to Alexander Alexakis, Ihor Ševčenko, and Alice-Mary Talbot. Any errors that remain are my own.

from the air, from the light, from the sky. Rather, a mixture of the beauty of the seasons, it is a bond of land and sea at their limits, although the limit thus (both) unites and separates their natures. A colossus in height, and cleaving the air, it strives somehow to reach even the sky. It is wide in breadth, and in length greater. In both dimensions there is beauty, but how much more! The stones are beautified by their quadrangular shape, while an admirable and finely (constructed) arrangement (beautifies) the shape of the tower, namely the shape of a delicate honey-comb; a hexagon raises its most beautiful shape to the stars and to the beauties of the firmament. Do not talk to me about ancient tower construction. That was not yet a tower, but its construction came to an end. But this tower has been raised to the greatest height, it stands alone, and guards the city. But more, it delights every sight and the city. It is a place of wonders, in the midst of the air, a kind of hollow of the breezes, a house of Aeolos. And contemplating the beauty, all the beauty of the world from above, it is a world of adornment for the eyes. From the earth (are seen) flowers, trees, meadows, foliage, springs, coppices, pastures, and streams; the vine heavy with innumerable fruits, many a wine-producing vine, and many a fruit bearing tree. And there is in some places even a beautiful mixture, for the vine is raised up on towering trees, branches together with beautiful tendrils, fruits together with grapes, and more, and beds of leaves, and stoas and roofs. Do you wish to know the whole prospect of the tower? Raise your eyes straight, look from nearby at the virtues of the earth...".

As was stated above, it is possible to identify the specific fortification tower that John Geometres was describing, namely the first tower on the inner line of the Theodosian land-walls of Constantinople, which stands at the point where that wall adjoins the wall running along the Sea of Marmara ("Tower 1", in Fig. 1)². This identification is suggested by several passages in the poem:

1. The poem describes a fortification tower, which guards the city from barbarians (lines 11 and 30).
2. The poet says that the tower stands at the junction of land and sea (lines 15-17: "it is a bond of land and sea at their limits, although the limit thus (both) unites and separates their natures").
3. The tower is hexagonal in its upper part (lines 23-26: "...an admirable and finely (constructed) arrangement (beautifies) the shape of the tower, namely the shape of a delicate honey-comb; a hexagon raises its most beautiful shape to the stars and to the beauties of the firmament"). This is true of tower number 1 of the land-walls, which is pentagonal in its lower parts, where it abuts the curtain wall (Fig. 1), but hexagonal above, where it rises

clear of the wall. Older, nineteenth-century photographs show that at its top the tower was given an additional facet on its southeast side, where it surmounts the thickness of the wall (Fig. 2).

4. The poet may imply that the tower he describes had recently been restored, or completed (lines 27-29). Drawing a contrast with the unfinished Tower of Babel, he says: "Do not talk to me about ancient tower construction. That was not yet a tower, but its construction came to an end. But this tower has been raised to the greatest height..."). Tower number 1 still displays in its upper part (i.e. in the portion of the tower that rises above the height of the land-walls) an inscription identifying the tower as that of the emperors Basil and Constantine³. This is one of two inscriptions appearing on the walls of Constantinople that mention these two emperors together; the other one is on the north tower of the gate of the Pege⁴. It is generally believed that these inscriptions record repairs made to the fortifications by the Emperors Basil II and Constantine VIII after the severe earthquake of 989⁵, which, according to Leo the

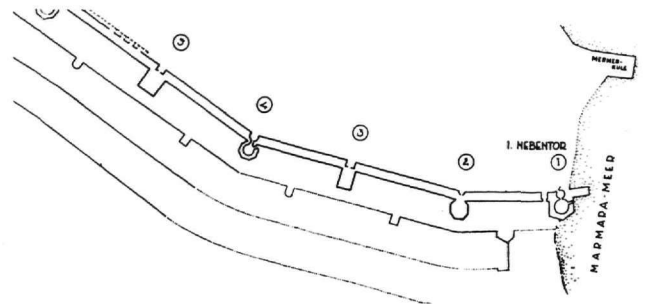

Fig. 1. Plan of the southern end of the land-walls of Constantinople. (After: B. Meyer-Plath - A. M. Schneider, *Die Landmauer von Konstantinopel*, II, 1943, pl. 1).

Deacon, brought down the "towers of Byzantium" as well as the dome of St. Sophia⁶. Thus the date of the reconstruction of tower number 1 that is indicated by its inscription fits with the date of the composition of the poem (second half of the tenth century). There may be a reference to the earthquake that necessitated the reconstruction in line 7 ("the victim of every form of violence... of earthquakes and tremors").

These considerations make an identification of the tower described in our poem with the first tower of the land-walls of Constantinople extremely likely. The only other possible candidates on the land-walls would be the two hexagonal towers attached to the "wall of Heraclius" at the Blachernae, which might also be said to be at the junction of land and sea (i.e. these two towers are near the point where the land-walls meet the Golden



Fig. 2. Inner land-wall of Constantinople, view of tower number 1 from the southwest, taken circa 1870. (After: Meyer-Plath - Schneider, *op.cit.*, pl. 25).

Horn)⁷. But the description is less apt for these towers, for they are, in fact, some seventy-five meters inland, while tower number 1 stands right at the water's edge. Furthermore, the poet stresses that his tower is one that "stands alone" (lines 29-30), and this characterization does not describe the hexagonal towers of the Blachernai well, since they are set in a clump together with other towers.

It could also possibly be argued that our tower was one of those on the sea-wall, fronting the Sea of Marmara⁸. But such a location also seems less likely on account of the description "stands alone", which better suits a corner position such as that occupied by tower number 1. In addition, there is another reference in the poem which suggests that our tower faced the suburbs of Constantinople on its land side, as would have been the case if it were part of the land-wall, and not the city itself, as

2. For plans, reconstructions, and views of this tower see F. Kriechen, *Die Landmauer von Konstantinopel*, I, Berlin 1938, pls 40, 41; B. Meyer-Plath - A. M. Schneider, *Die Landmauer von Konstantinopel*, II, 1943, pls 1, 4, 12, 25; W. Müller-Wiener, *Bildlexikon zur Topographie Istanbuls*, Tübingen 1977, figs 328-329.

3. +Πύργος Βασιλείου καὶ Κωνσταντίνου πιστῶν ἐν Χ(ριστ)ῶ α[ὐ]τοκρατόρων εὐσεβεῖς βασιλεῖς Ῥωμ(αί)ων+. Meyer-Plath - Schneider, *op.cit.*, p. 123.

4. Tower 36; *Ibid.*, p. 129.

5. A. Van Millingen, *Byzantine Constantinople, The Walls of the City and Adjoining Historical Sites*, London 1899, p. 101; R. Janin, *Constantinople byzantine, développement urbain et répertoire topographique*, Paris 1964, p. 268.

6. ...τὰ τε πύργωματα τοῦ Βυζαντίου πρὸς γῆν κατερίπωσε... Bonn ed., p. 175.24-176.1. On this earthquake, see G. Downey, *Earthquakes at Constantinople and Vicinity, A.D. 342-1454*, *Speculum* 30 (1955), p. 599-600.

7. Van Millingen, *op.cit.*, p. 165; Müller-Wiener, *op.cit.*, figs 343, 347, 351.

8. F. Dirimtekin, *Marmara Surları*, Istanbul 1953; Müller-Wiener, *op.cit.*, p. 312-319, figs 333, 337-367.

would have occurred if it were attached to the sea-wall. The last preserved lines of the poem (lines 46-48), ask: “Do you wish to know the whole prospect of the tower? Raise your eyes straight, look from nearby at the virtues (ἀρετὰς) of the earth”. It is possible that these words are a reference to the suburban park and palace of the *Aretai*, rather than just a figure of speech⁹. This district was described by the historian Anna Commena as being “near the city” of Constantinople. She wrote: “It is elevated above the plain, and, to those standing and looking on it from below, gives the appearance of rising into a ridge, inclining one of its flanks towards the sea, and the other towards Byzantium, and the two others to the North and to the West, being exposed to all the winds”¹⁰. Modern scholars have located the *Aretai* either in the area of Maltepe¹¹, which faces the northern portion of the land-walls, or further to the south, on the high ground west of Haznadarçiftlik, three kilometers north of Bakirköy¹². If our poem does indeed refer to the *Aretai*, then, since it says that this hill was visible from the tower, two conclusions follow: 1) The tower in question was part of the land-walls; it cannot have been attached to the sea-wall. 2) Since our tower should be identified as the one on the extreme southern end of the land-wall, the park of the *Aretai* must have been situated well south of the region of Maltepe.

The poem, then, acquires interest as an empirical confirmation of reconstruction work on the walls of Constantinople by Basil II and Constantine VIII after the earthquake of 989. At least in the eyes of the poet, this reconstruction went beyond mere repairs, for he implies that the emperors heightened the tower, making it more conspicuous than the other towers of the Theodosian wall (lines 29-30 “...this tower has been raised to the greatest height, it stands alone, and guards the city”). The most interesting aspect of this poem, however, is not the factual information that can be gleaned from it, but what it reveals about the poet’s reactions to a newly built monument of military architecture. It is noteworthy that the author devotes very few lines explicitly to the defensive functions of the tower (e.g. lines 8-11...: “a tower of strength... overcoming... the assaults and machines of the barbarians”). The greater part of the poem, as it survives, is devoted to praising the beauties of the construction and shape of the tower, and especially to the views to be obtained from it as a look-out point over the countryside and perhaps over the *Aretai* park. The extensive description of the charms of the landscape to be seen from the tower (lines 34 to 45) is more than mere literary embellishment, for we know that at this time, in the tenth century, other fortifications were being constructed with such a double purpose, as military

defenses and as look-out points that were intended to provide aesthetic pleasure. There is a reference to such miradors at the tenth-century palace and city which the Armenian monarch Gagik built at Aght’amar, on an island in Lake Van¹³. The description of Aght’amar by the contemporary author Thomas Artsruni refers to the fortified wall enclosing Gagik’s city with its gardens; this wall was both “fearsome”, and “adorned” with “very high and broad-based towers and raised bastions, which had in them deep niches with pleasure seats, where the king often took his ease with his sons and noble courtiers”¹⁴. The tenth-century palace at Madinat al-Zahra’ in al-Andalus certainly contained pavilions that were constructed as look-outs giving onto terraced gardens¹⁵. It has been suggested that this palace also may have featured miradors on its buttress-towers¹⁶, such as were built later into the fortifications of the Alhambra palace at Granada¹⁷. The poem of John Goemetres, therefore, informs us of an aesthetic of fortifications in tenth-century Byzantium for which there is also evidence in other cultures at this time. It demonstrates that even though defensive towers were a necessity, they could be made a virtue, too, and that an appreciation of the beauty of castles was not only an invention of nineteenth-century Romanticism.

9. On the *Aretai*, see Janin, *op.cit.*, p. 138, 443; H. Maguire, A Description of the *Aretai* Palace and its Garden, *Journal of Garden History* 10 (1990), p. 209-213.

10. ...τὰς καλουμένας Ἀρετὰς. Τόπος δὲ οὗτος ἀγχοῦ τῆς πόλεως διακειμένος, ὑπερκείμενος μὲν τῆς πεδιάδος καὶ τοῖς κάτωθεν ἰσταμένοις καὶ πρὸς τοῦτον ὀρῶσιν εἰς λοφίαν ἀνατεινόμενος καὶ τὴν ἑτέραν μὲν πλευρὰν πρὸς θάλατταν ἀπνεύων, κατὰ δὲ τὴν ἑτέραν πρὸς τὸ Βυζάντιον, ταῖς δὲ γε λοιπαῖς δυσὶ πρὸς ἄρκτον καὶ δύσιν, παντὶ ἀνέμῳ καταπνεύμενος... Alexiad, 2.8.5; ed. B. Leib, I, Paris 1937, p. 90.4-11.

11. A. M. Schneider, *Byzanz, Vorarbeiten zur Topographie und Archäologie der Stadt*, Berlin 1936, p. 81.

12. Janin, *op.cit.*, p. 138, 443.

13. For a survey of the buildings at Aght’amar, with earlier bibliography, see S. Der Nersessian - H. Vahramian, *Aght’amar* (*Documenti di Architettura Armena* 8), Milan 1974.

14. *History of the House of the Artsrunik’*, translation and commentary by R. W. Thomson, Detroit 1985, p. 356. I am grateful to Lynn Jones for this reference.

15. D. Fairchild Ruggles, *The Mirador in Abbasid and Hispano-Umayyad Garden Typology*, *Muqarnas* 7 (1990), p. 73-82, esp. 75-76.

16. F. Hernández Giménez, *Madinat al-Zahra’: Arquitectura y Decoración*, Granada 1985, p. 61-62; cited and discussed by Fairchild Ruggles, *op.cit.*, p. 76-78, fig. 8.

17. For example, the Torre de las Infantes; O. Grabar, *The Alhambra*, 2nd ed., Sebastopol 1992, p. 66.